

Control

EFC18

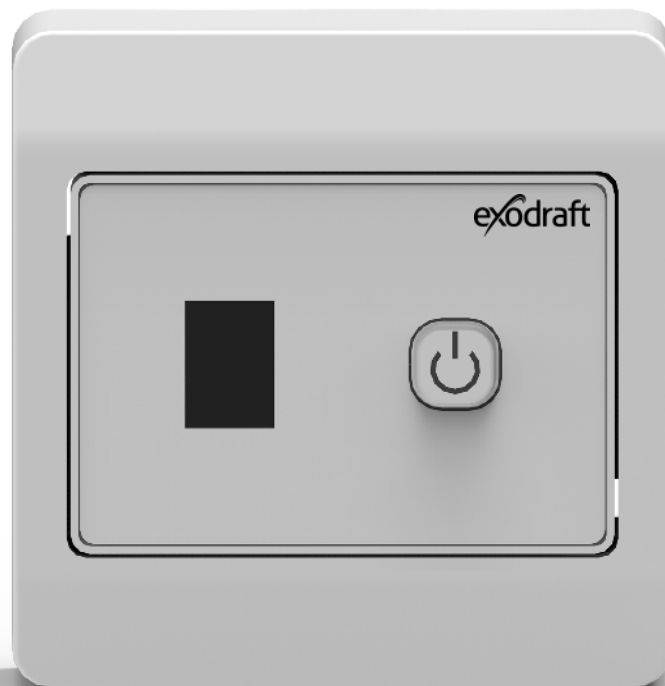

UK | Read and save these instructions!

exodraft
Your energy. Optimized.

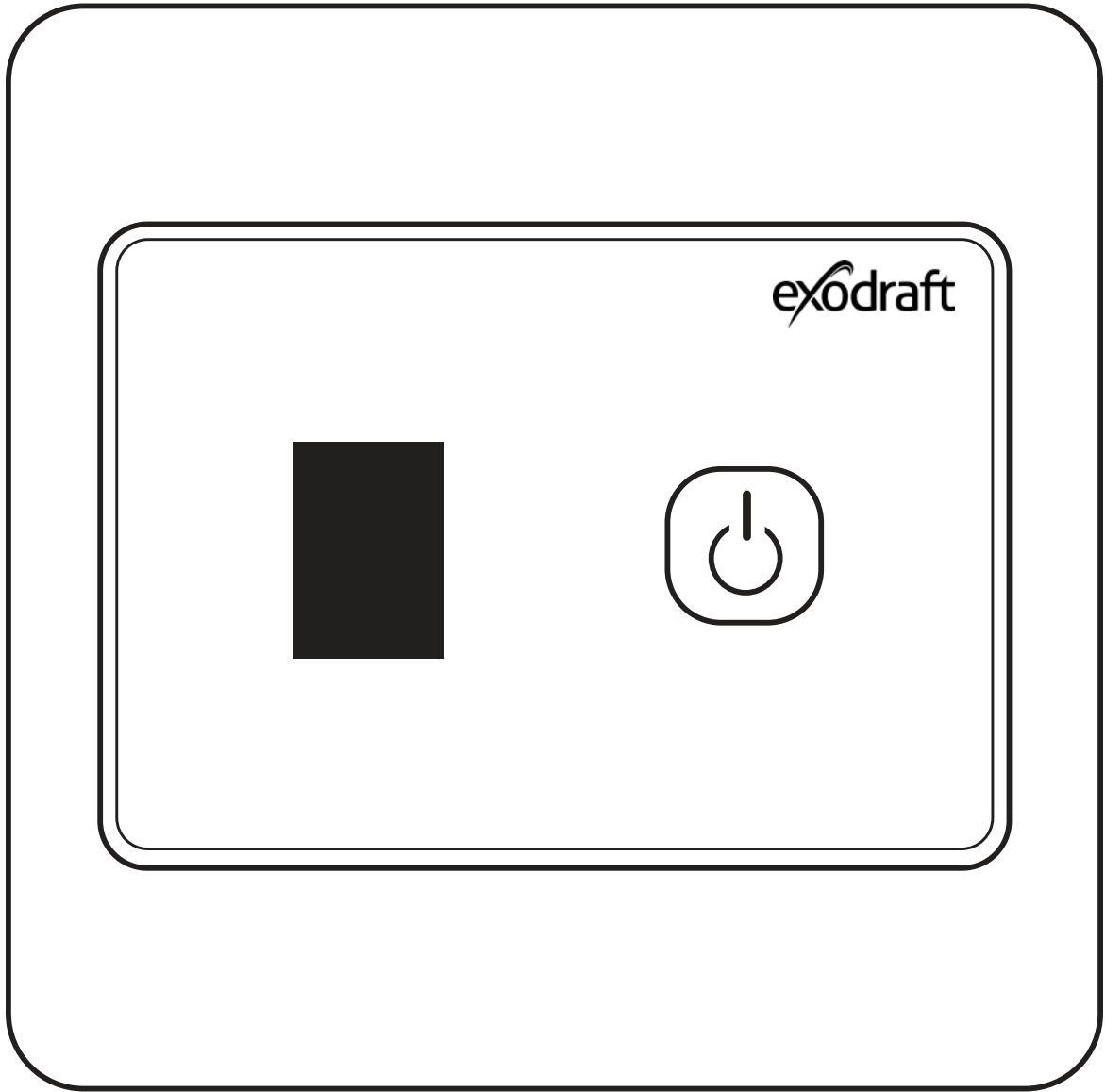

exodraft

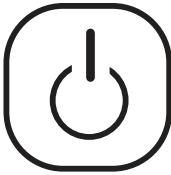

Control | EFC18

Content

Product information	7
Scope of supply	7
Accessories	7
Technical specifications	9
Construction and components	10
Installation	10
Installation instructions	12
Settings	13
Daily use	13
UK Conformity Assessed	14
Declaration of Conformity	15



How to use this manual

This manual has been prepared based on the specific product and contains relevant technical information and installations guides.

Accessories and spare parts are not covered by this manual. Please refer to the individual manuals of these components.

This installation manual does not contain any system design documentation.

Failure to observe instructions marked with a danger symbol may result in personal injury and/or damage to the product.

Errors and omissions excepted.



Disposal

Electrical and electronic equipment (EEE) often contain materials, components and substances that may harm the environment or be hazardous to your health. Products (WEEE) marked with the 'crossed-out wheeled bin' symbol should be disposed of separately from other waste at the end of its life. Though legislation may differ from country to country we strongly advise that electrical and electronic waste is separated from other waste and disposed of according to national legislation to protect the environment and personnel that may come into contact with waste.

Symbols

The following symbols may be used in the manual to draw attention to danger or risk of personal injury or damage to the product.



General prohibition

Failure to observe instructions marked with the prohibited symbol may result in extreme danger or serious personal injury.



General attention

Marks a dangerous situation that, in the worst-case scenario, can cause serious personal injury or significant damage to the product.



General warning

Failure to observe instructions marked with a danger symbol may result in personal injury and/or damage to the product.



Electricity hazard/High Voltage

Marks a situation in which caution is advised due to the risk of high voltage electric shock which can cause serious personal injury or significant damage to the product.



Connect an earth terminal to the ground

Failure to observe instructions marked with a danger symbol may result in personal injury and/or damage to the product.



Permitted and approved

Permitted and approved method of installation.



Prohibited and not approved

Prohibited and not approved method of installation.



Warning

To minimise the risk of fire, electric shock, personal injury and/or damage to the product please observe the following:

- Please always read the manual and only use the product in accordance with the manufacturer's instructions. If in doubt, contact one of the Exodraft specialized dealers.
- All installations must be carried out by properly qualified personnel in accordance with national legislation and regulations.
- This product must be earthed. Get assistance from an qualified electrician when in doubt.
- This product must always be disconnected under the installation.
- Prior to servicing the product, disconnect the power and ensure that it cannot accidentally be reconnected.
- Exodraft always recommends the use of a smoke alarm when a solid fuel open fire is installed.
- If the Exodraft fan system has been designed for solid fuel/multi fuel installations, please ensure that the design meets the requirements of BS EN15287-1. If this cannot be achieved, a smoke alarm must be installed in the same room as the heat appliance.

Product information

Exodraft control EFC18 is, like the Exodraft chimney fan, designed to be used with fire places, stoves and boilers for solid fuel.

Using the temperature sensor, the control unit can stop and start the chimney fan automatically. Simple programming allows the EFC18 to be used with either an open fire, a stove or boiler.

If more fuel needs to be added whilst the fire is burning the fan speed can be increased to full for 3 minutes by a single press on the ON/OFF button.

The fan voltage and speed has an adjustment between 1 and 9.

Incorrect use may result in problems with soot, chimney fires, etc. which might damage the product. Please check out this site for advice about the product:

www.exodraft.com

Scope of supply

- Exodraft EFC18
- Temperature sensor
- Installation manual and user instructions

Accessories

The table below shows the accessories and spare parts available for the RHG-models.

Accessories*
Temperature sensor
Isolation switch

*This manual does not describe the specific use of accessories. We refer to the separate manuals for such components. For more details contact your Exodraft dealer.

Warranty

All Exodraft products are covered by a 2-year guarantee as per European consumer rights legislation. For some countries an extended period of guarantee may apply depending on either national legislation or other clearly stipulated conditions. Customer complaints must be handled by a specialised dealer or wholesaler (preferably where the Exodraft product has been bought originally). An updated list of Exodraft specialised dealers can be found on our website for the country in question.

Exodraft products must always be installed by properly qualified personnel. Exodraft reserves the right to change these guidelines without prior notice.

The warranty and liability does not cover instances regarding personal injury or damage to property or the product that can be ascribed to one or more of the following causes:

- Failure to follow this installation and operation manual
- Incorrect installation, start-up, maintenance or servicing
- Improper repairs
- Unauthorised structural modifications made to the product
- Installation of additional components that have not been tested/approved with the product
- Any damage resulting from continued use of the product despite an evident defect
- Failure to use original spareparts and accessories
- Failure to use the product as intended
- Exceeding or failure to meet the limit values in the technical data
- Force majeure

Technical specifications

The Exodraft EFC18 flue gas control is a 9-speed control with integrated temperature monitoring for safety switching and automatic start/stop of the chimney fan. The control also has a start function for producing a stronger chimney draught to ensure easy lighting. The EFC18 control comprises control console and temperature sensor for mounting under the chimney fan. The chimney fan is activated by pressing the button on the front of the control.

During the first seven minutes the start function ensures maximal chimney draught, enabling lighting in the room without soot and dust. Following the 7-minute start operation the chimney fan will return to the last set level. The control button has to be pressed again if wood is added. This runs the chimney fan for 3 minutes at maximal speed. The door or glass panel can now be opened without fumes escaping and the added wood lights more quickly. The control also has temperature monitoring under the chimney fan. If someone forgets to switch on the chimney fan it is force-switched. This provides protection from overheating of the chimney fan, but does not replace manual switching.

Technical data

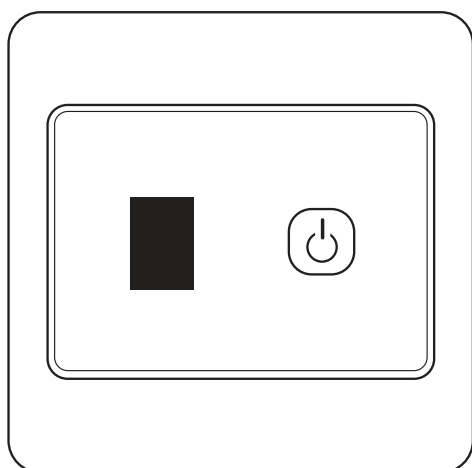

Description	EFC18
H x W x D [mm]	85 x 85 x 32,5
Max. load	1.2 A
Fuse	T 1.25 A
Voltage	230 VAC, 50 Hz
Sensor workspace	-50 °C to +400 °C
Temperature sensor	0°C to +40°C
Density class	IP 30
Material	ABS
Colour	White
Suitable for the following chimney fans	RS9/12/14/16 and RSV9/12/14

Construction and components

1	EFC18
2	Temperature sensor

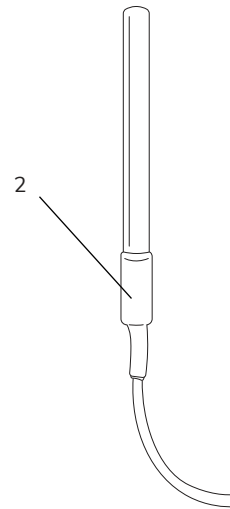
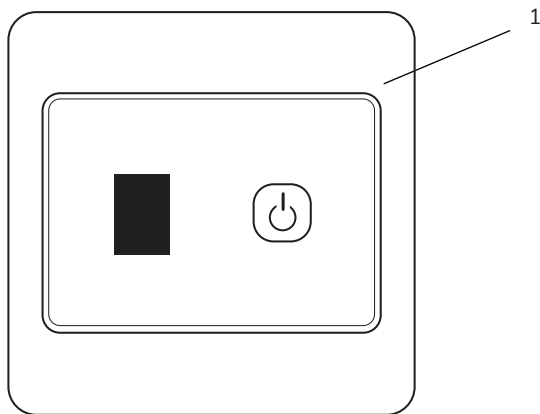

Installation

EFC18

- To separate the panel, first remove the frame.
- There are two screws at the back of the frame which hold the panel in place on the base. Loosen these and take off the panel.
- Fit the base on a wall.

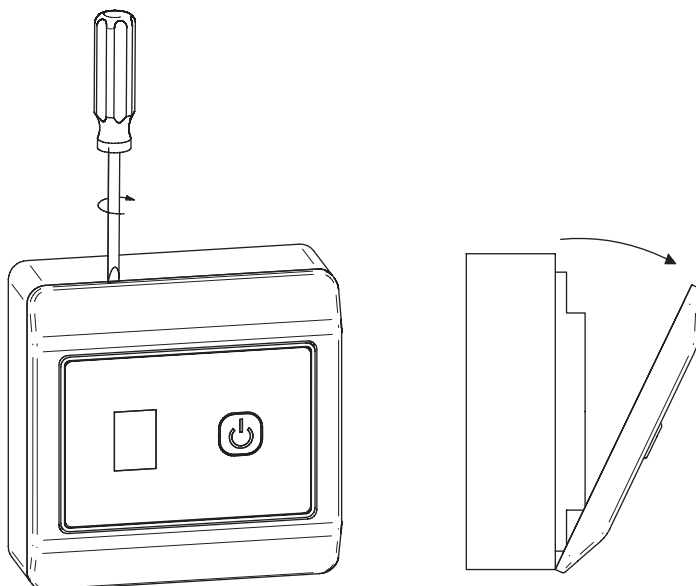

Temperature sensor

- Fit the sensor to the base plate of the chimney fan.
- The sensor should be positioned. See picture below

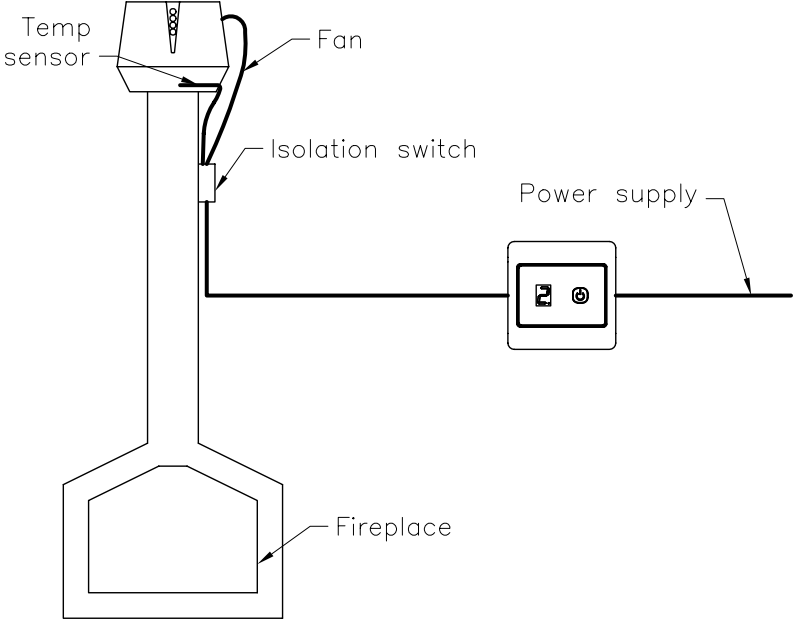

RSV	RS
<p>If an FRx-AFD flange is used, remove the plug from the pipe and insert the sensor. Tighten the screw (A).</p>	<p>If an FRx-AFD flange is used, remove the plug from the pipe and insert the sensor. Tighten the screw (A).</p>

Installation instructions

Connect the EFC18 and the temperature sensor as in the diagram below (RS/RSV).

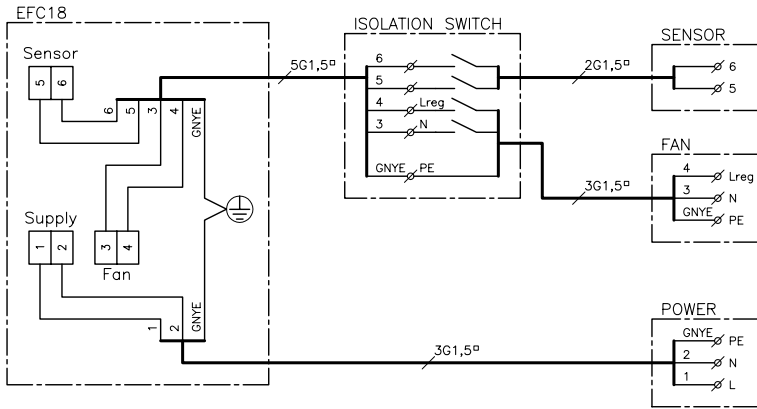

Connect the EFC18 and the temperature sensor as in the diagram below (RSHT).



Always switch off the electricity supply before opening the control unit.

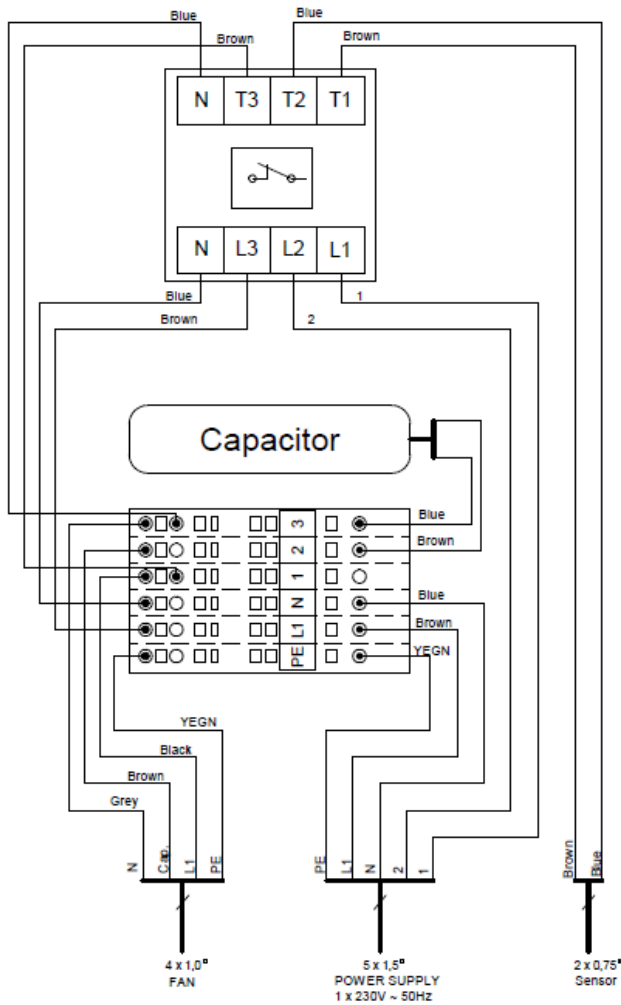

Settings

The EFC18 is set initially so that the temperature sensor starts and stops the chimney fan at either 20 °C, 40 °C or 80 °C. The factory setting is 40 °C.

Setting the temperature

Step	Action
1	The control must be standby (shows "—" in display).
2	Press and hold the button in for 5 seconds and the figure displayed will change to 0,1, 2 or 3.
3	When the required number is displayed, hold down the button until a horizontal line appears ("—").

Setting options:

0 = Fitted without sensor

1 = Automatic start / stop of chimney fan, 20 °C (open fire / closed stove / boiler)

2 = Automatic start / stop of chimney fan, 40 °C (open fire / closed stove / boiler)

3 = Automatic start / stop of chimney fan, 80 °C

(alternative setting for closed stove / boiler: delayed start / rapid stop)

Daily use

Start	The fire place is made ready for lighting and the button on the EFC18 is activated by pressing once. The fire is lit and the chimney fan runs at full speed for 7 mins., and then slows down to the previous level. The speed of the chimney fan can be changed at any time from 1 – 9 by holding down the button.
Refuelling	When the sensor is active (red dot in display), the refuelling option can be activated by pressing the button briefly. The chimney fan increases speed to maximum for 3 mins.
Automatic stop	When the temperature falls below 20 °C, 40 °C or 80 °C depending on the setting, the 45 minutes post purge period will start. The red dot in the display will start to flash.
Automatic operation	When the red dot in the display is illuminated, the temperature around the sensor is above the set temperature, meaning that the chimney fan can only be stopped by switching off the electric supply.
Sensor error	If there is an error with the sensor, an "E" flashes on the display. Check the installation.



UK Conformity Assessed



**Exodraft a/s
Industrivej 10
DK-5550 Langeskov**

Hereby declares that the following products:

EFC18

Were manufactured in conformity with the provisions of the following regulations:

The Supply of Machinery (Safety) Regulations 2008

Electrical Equipment (Safety) Regulations 2016

Electromagnetic Compatibility Regulations 2016

Langeskov, 01-11-2022
Managing Director
Anders Haugaard



Declaration of Conformity

DK: EU-Overensstemmelseserklæring
 GB: Declaration of Conformity
 DE: EU-Konformitätserklärung
 FR: Déclaration de conformité de l'Union Européenne
 NO: EU-Samsvarserklæring
 PL: EU Deklaracja zgodności

NL: EU-Conformiteits verklaring
 SE: EU-Överensstämmelsedeklaration
 FI: EU-Vaatimustenmukaisuusvakuutus
 IS: ESS-Samræmisstaðfesting
 IT: Dichiarazione di Conformità Unione Europea



Exodraft a/s
Industrivej 10
DK-5550 Langeskov

Erklærer på eget ansvar, at følgende produkter:
 Hereby declares that the following products:
 Erklärt hierdurch auf eigene Verantwortung, daß folgende Produkte:
 Déclare, sous sa propre responsabilité, que les produits suivants:
 Erklærer på eget ansvar at følgende produkter:
 Niniejszym oświadczam, że następujące produkty:

Veklaart dat onderstaande producten:
 Deklarerar på eget ansvar, att följande produkter:
 Vastaa siltä, että seuraava tuote:
 Staðfesti à eigin àbyrgð, að eftirfarandi vörur:
 Dichiaro con la presente che i seguenti prodotti:

EFC18

Som er omfattet af denne erklæring, er i overensstemmelse med følgende standarder:
 Were manufactured in conformity with the provisions of the following standards:
 Die von dieser Erklärung umfaßt sind, den folgenden Normen:
 Auxquels s'applique cette déclaration sont en conformité avec les normes ci-contre:
 Som er omfattet av denne erklæring, er i samsvar med følgende standarder:
 Zostały wyprodukowane zgodnie z warunkami określonymi w następujących normach:

Zijn vervaardigd in overeenstemming met de voorschriften uit de hieronder genoemde normen en standaards:
 Som omfattas av denna deklaration, överensstämmer med följande standarder:
 Jota tämä selvitys koskee, on seuraavien standardien mukainen:
 Sem eru meðtalin í staðfestingu Pessari, eru í fullu samræmi við eftirtalda staðla:
 Sono stati fabbricati in conformità con le norme degli standard seguenti:

EN 60335-1, EN 60335-2-80, DS/EN ISO 12100: 2011

I.h.t bestemmelser i direktiv:
 In accordance with
 Entsprechen gemäß den Bestimmungen der folgenden Richtlinien:
 Suivant les dispositions prévues aux directives:
 I.h.t bestemmelser i direktiv:
 Zgodnie z:

En voldoen aan de volgende richtlijnen:
 Enligt bestämmelserna i följande direktiv:
 Seuraavien direktiivien määräysten mukaan:
 Med tilvisun til ákvarðana eftirlits:
 In conformità con le direttive:

Maskindirektivet:
 The Machinery Directive:
 Richtlinie Maschinen:
 Directive Machines:
 Maskindirektivet:
 Dyrektywę maszynową:

De machinerichtlijn:
 Maskindirektivet
 Konedirektiivi:
 Vèlaeftirlitið:
 Direttiva Macchinari:

2006/42/EF-EEC/-EWG/-CEE

Lavspændingsdirektiv:
 The Low Voltage Directive:
 Niederspannungsrichtlinie:
 Directive Basse Tension:
 Lavspenningsdirektivet:
 Dyrektywę Niskonapięciową

De laagspanningsrichtlijn:
 Lågspänningsdirektivet:
 Pienjännitedirektiivi:
 Smáspennueftirlitið:
 Direttiva Basso Voltaggio:

2014/35/EC

EMC-direktivet:
 And the EMC Directive:
 EMV-Richtlinie:
 Directive Compatibilité Electromagnétique:
 EMC-direktivet:
 Dyrektywę EMC – kompatybilności elektromagnetycznej

En de EMC richtlijn:
 EMC-direktivet:
 EMC-direktiivi:
 EMC-efirlitið:
 Direttiva Compatibilità Elettromagnetica:

2014/30/EC

Langeskov, 01-11-2022
 Adm. direktør
 Managing Director
 Anders Haugaard

Algemeen directeur
 Geschäftsführender Direktor
 Président Directeur Général
 Verkställande direktör
 Toimitusjohtaja
 Framkvemdastjóri
 Direttore Generale

DK: Exodraft a/s

Industrivej 10
DK-5550 Langeskov
Tel: +45 7010 2234
Fax: +45 7010 2235
info@exodraft.dk
www.exodraft.dk

SE: Exodraft a/s

Kalendevägen 2
SE-302 39 Halmstad
Tel: +46 (0)8-5000 1520
info@exodraft.se
www.exodraft.se

NO: Exodraft a/s

Storgaten 88
NO-3060 Svelvik
Tel: +47 3329 7062
info@exodraft.no
www.exodraft.no

UK: Exodraft Ltd.

24 Janes Meadow, Tarleton
GB-Preston PR4 6ND
Tel: +44 (0)1494 465 166
Fax: +44 (0)1494 465 163
info@exodraft.co.uk
www.exodraft.co.uk

DE: Exodraft a/s

Niederlassung Deutschland
Soonwaldstr. 6
DE-55569 Monzingen
Tel: +49 (0)6751 855 599-0
Fax: +49 (0)6751 855 599-9
info@exodraft.de
www.exodraft.de

FR: Exodraft sas

78, rue Paul Jozon
FR-77300 Fontainebleau
Tel: +33 (0)6 3852 3860
info@exodraft.fr
www.exodraft.fr

Your energy. Optimized.

The logo for Exodraft, featuring the word "exodraft" in a bold, lowercase sans-serif font. The letter "x" is stylized with a curved line that loops around the top and bottom of the letter, suggesting motion or energy.